



## Application Note

AN0006

# SK5103 FlexMatrix Medical Keyboard Evaluation Kit User Guide

Associated Part Family: SK5103, KIT-SK5103EVK

## 1. Overview

The evaluation kit has been designed to accelerate your development of your own keyboard product using SK5103 FlexMatrix medical keyboard controller. The FlexMatrix keyboard controllers provide developers the most cost-effective, shortest time-to-market solutions to the industrial customers. The SK5103 is designed for medical applications such as ultrasound devices.

Part# KIT-SK5103EVK - Evaluation kit for SK5103

## 2. Kit Contents

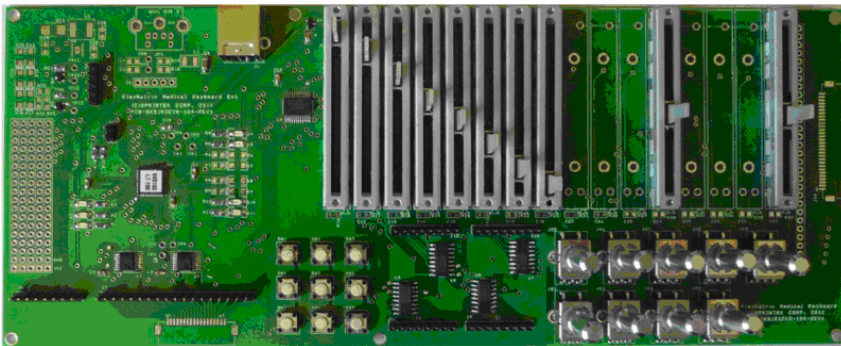

ASY-SK5103EVK-*vvv*  
(*vvv* is IC version #)



USB A To B Cable

### 3. Board

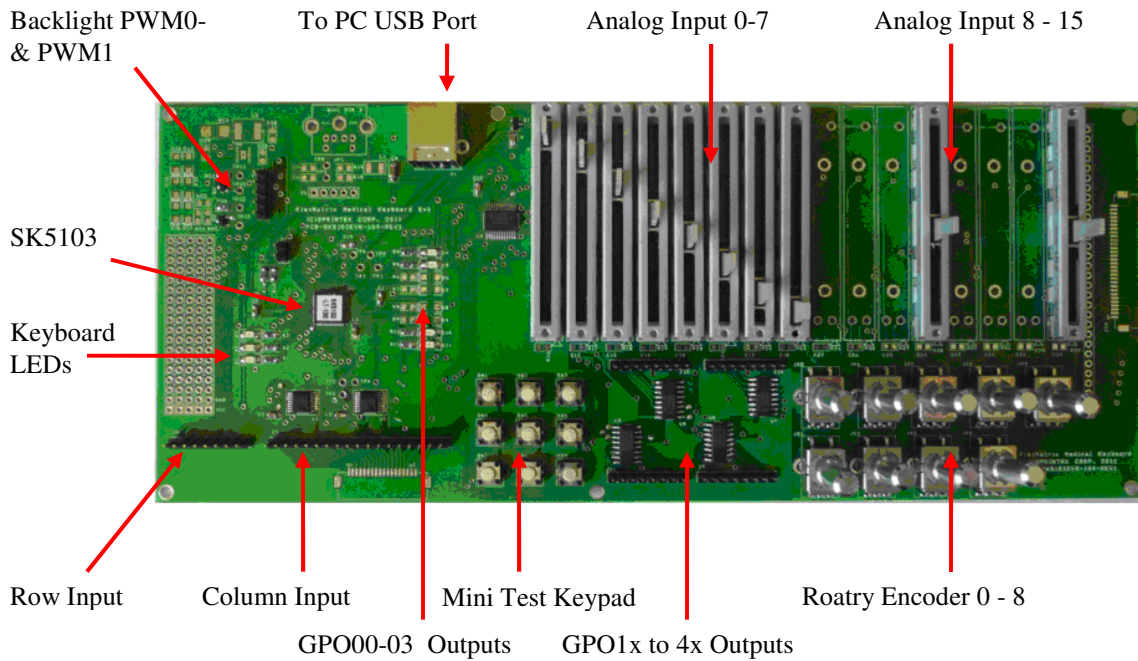

### 4. Get Started

#### Setup:

- 1) Connect SK5103 evaluation board to PC via the USB cable in the kit
- 2) Install FlexMatrix Communicator software for SK5103 to your PC.
- 3) Install FlexMatrix Editor, Programmer, Tester software to your PC.

The software can be downloaded from <http://www.sprintek.com/support/Downloads.aspx>.

### 5. Helpful Documents

| Doc#   | Description  |
|--------|--|
| DS0015 | SK5103 USB FlexMatrix Medical Keyboard Encoder Datasheet |
| AN0002 | Customize FlexMatrix Keyboard Controllers                |

# 6. Evaluation Board Schematic

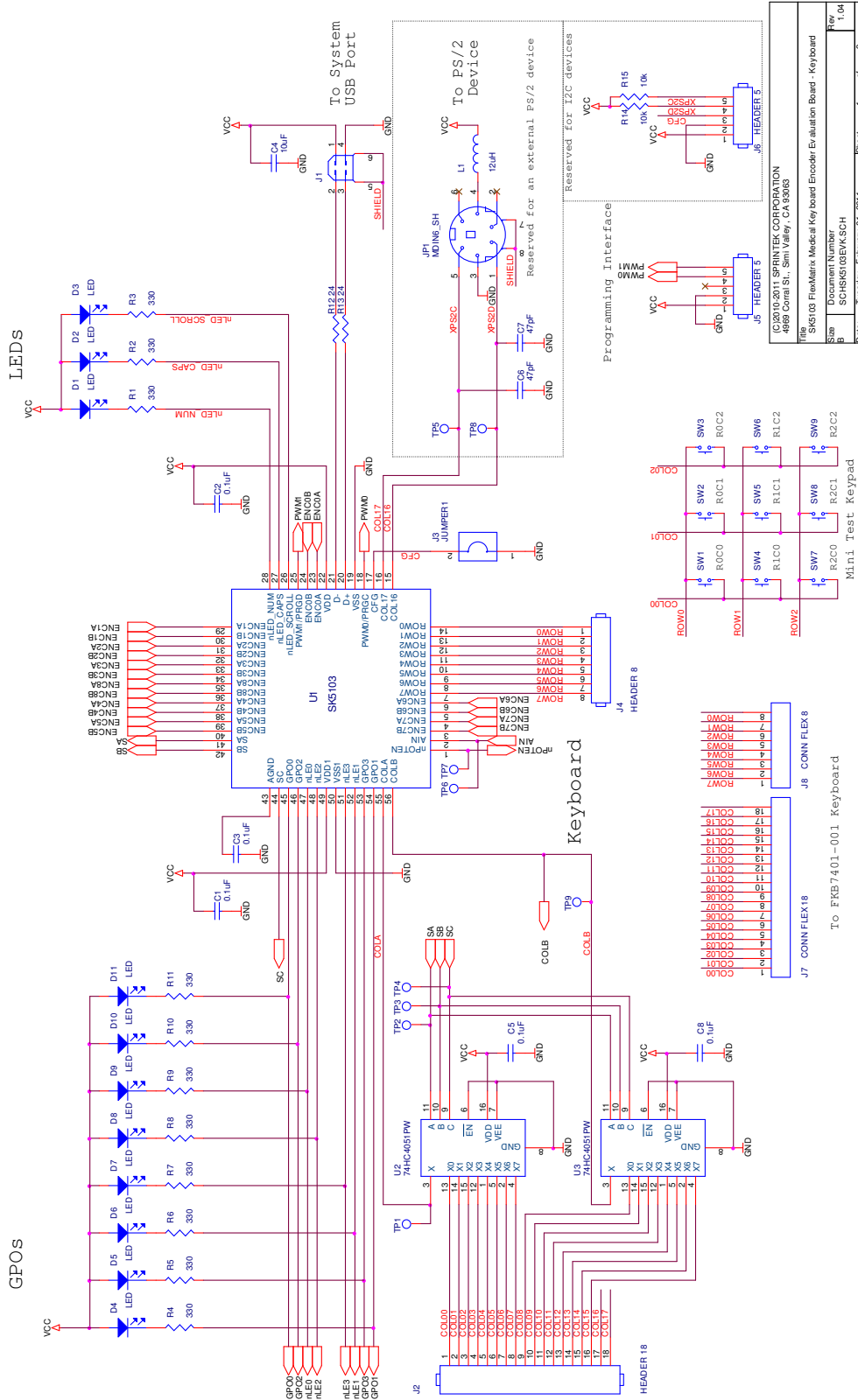

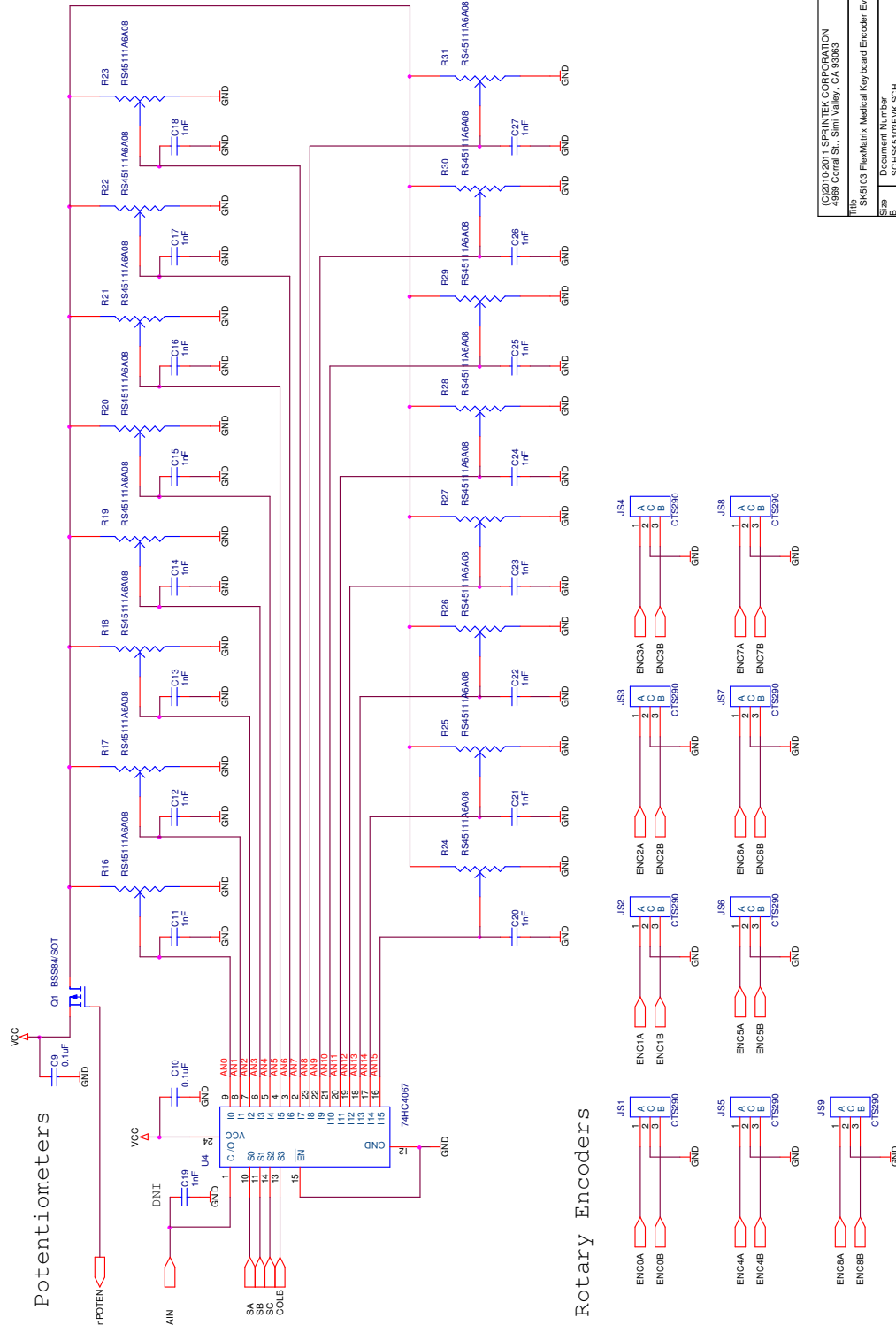

|  |                            |          |        |
|--|----------------------------|----------|--------|
| C:\2010\011_SPRINT\CORPORATION   |                            |          |        |
| 4988 Corral St., Simi Valley, CA 92683   |                            |          |        |
| Title: SK5103 FlexMatrix Medical Keyboard Encoder Evaluation Board - Peripherals 1 |                            |          |        |
| Sheet  | Document Number            | Revision | Rev    |
| 1  | SK5103EVBK-SOH             | 1.04     | 1.04   |
| Date:  | Tuesday, February 01, 2011 | Sheet    | 2 of 3 |

Expanded GPOs

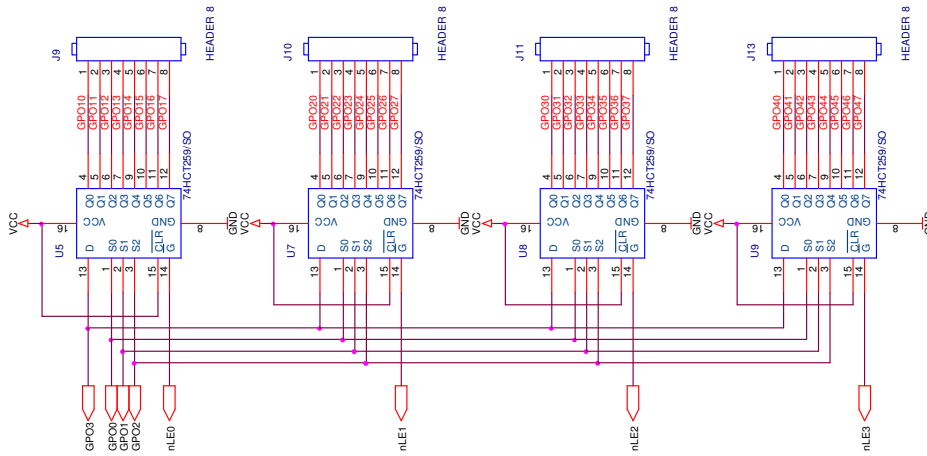

FWMs

Note: Demo only. Up to 14 LEDs per LED string.

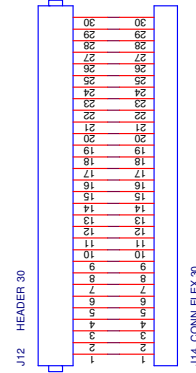
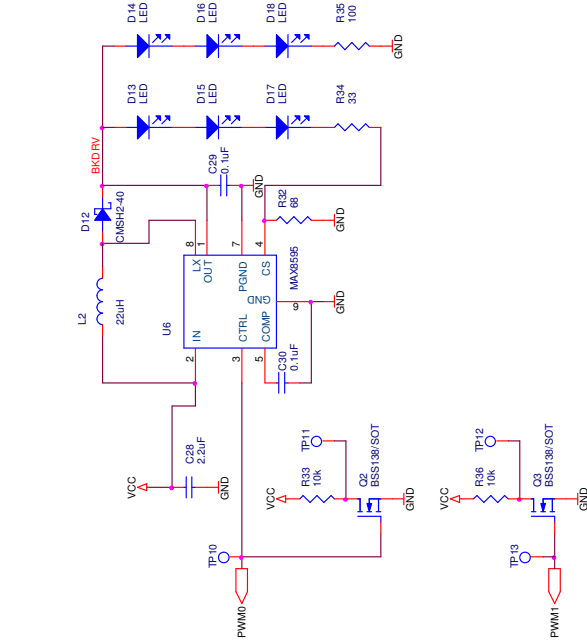

|  |   |       |        |
|--|---|-------|--------|
| IC20102011, SPRINTK CORPORATION<br>4888 Contra St., San Jose, CA 95128 |   |       |        |
| Title  | S05100 FlexMatrix Medical Keyboard Encoder Evaluation Board - Peripherals 2 |       |        |
| Size   | Document Number   | Rev   |        |
| Date   | SCHSKG103EVA.SCH  | 1.04  |        |
|  | Tuesday, February 01, 2011  | Sheet | 3 of 3 |

## 7. Support

To obtain information about Sprintek Corporation or FlexMatrix keyboard controller family sales and technical support, reference the following information.

**Sprintek Corporation**

4969 Corral St.

Simi Valley, CA 93063, USA

Phone: 805.405.8787

Web Site: <http://www.sprintek.com>